

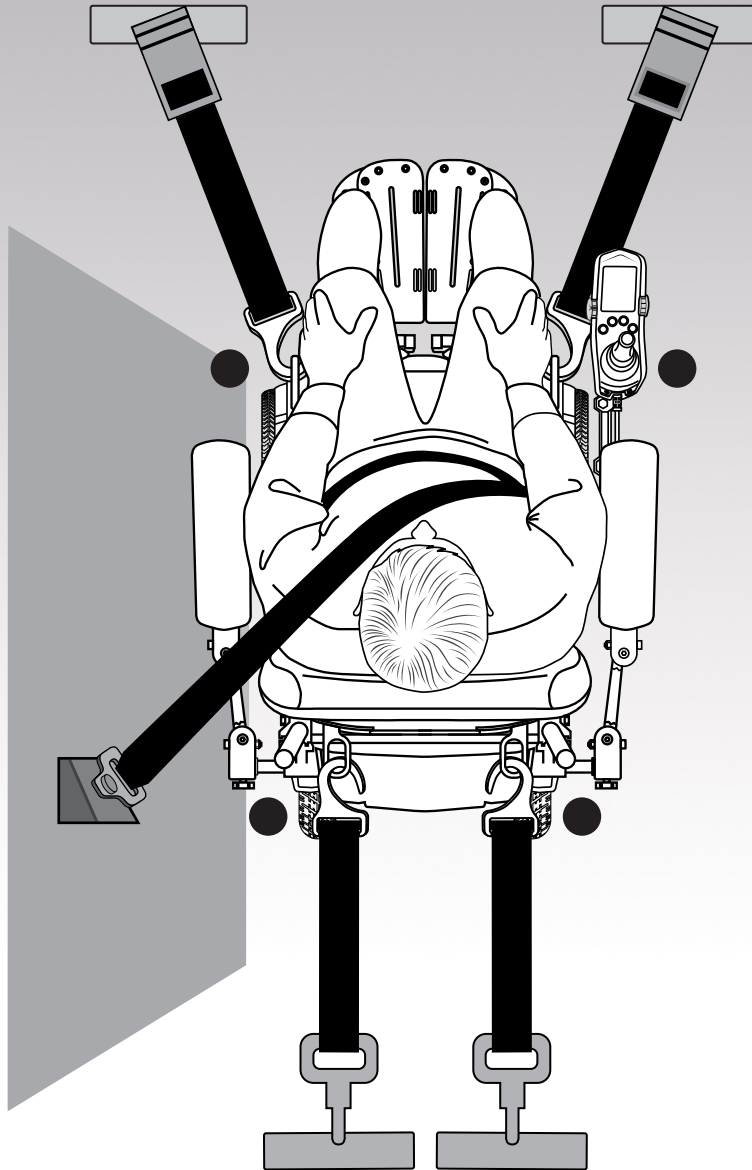

# Transit Securement Systems Guide

BASIC OPERATION INSTRUCTIONS FOR OCCUPIED AND UNOCCUPIED TRANSIT



**Occupied**

	or

**Unoccupied**

	or

**QUANTUM**<sup>®</sup>

PROVIDING GREATER INDEPENDENCE

● = 

	or	

**⚠ WARNING!**

**A Quantum Rehab Provider or a qualified technician must perform the initial setup of this power chair and must perform all of the procedures in this manual.**

The symbols below are used throughout this owner's manual and on the power chair to identify warnings and important information. It is very important for you to read them and understand them completely.

**⚠ WARNING!**

Indicates a potentially hazardous condition/situation. Failure to follow designated procedures can cause either personal injury, component damage, or malfunction. On the product, this icon is represented as a black symbol on a yellow triangle with a black border.

**■ MANDATORY!**

These actions should be performed as specified. Failure to perform mandatory actions can cause personal injury and/or equipment damage. On the product, this icon is represented as a white symbol on a blue dot with a white border.

**⊘ PROHIBITED!**

These actions are prohibited. These actions should not be performed at any time or in any circumstances. Performing a prohibited action can cause personal injury and/or equipment damage. On the product, this icon is represented as a black symbol with a red circle and red slash.

**Intended Use**

The intended use of this Pride Mobility Products device is to provide mobility assistance to persons with mobility impairment who have the capacity to operate a motorized mobility power chair in an indoor/outdoor environment.

**Regarding Devices for Prescription Use**

Our mobility products and their components are available for sale either as retail ("over-the-counter") or with a prescription. When prescribed, the following statement is applicable.

**⚠ WARNING!**

**CAUTION!** Federal law restricts this device to sale by or on the order of a physician or other certified personnel licensed by the law of the State (US only) or region in which this personnel practices to use or order the use of this device.

*NOTE: These instructions are compiled from the latest specifications and product information available at the time of publication. We reserve the right to make changes as they become necessary. Any changes to our products may cause slight variations between the illustrations and explanations in this manual and the product you have purchased. The latest/current version of this manual is available on our website.*

*NOTE: This product is compliant with WEEE, RoHS, and REACH directives and requirements.*

*NOTE: This product meets IPX4 classification (IEC 60529).*

*NOTE: This product and its components are not made with natural rubber latex. Consult with the manufacturer regarding any after-market accessories.*

*NOTE: For more information regarding patents, refer to <http://www.pridemobility.com/patents>.*



## Table of Contents

---

Introduction.....	4
Label Information .....	5
Definitions .....	5
User Safety Information .....	6
Protocol and Procedures.....	6
Securing the Power Chair.....	7
Securing the Power Chair Occupant .....	10
Transit Securement System .....	12
Important Points to Remember .....	13
Appendix: Declarations .....	14

**ADVISORY STATEMENT REGARDING CERTAIN COMPONENTRY INCORPORATED BY THIRD-PARTY MANUFACTURERS INTO FINISHED POWER CHAIRS:** When Quantum Rehab power bases, seating systems, or other components are incorporated into a finished power chair manufactured or assembled by any third party, that third party is responsible to assure the safety, functionality, and legal compliance of the finished power chair. Quantum Rehab makes no representation concerning the safety, functionality, or legal compliance of the finished power chair or its componentry manufactured by a third party. While Quantum Rehab makes every effort to assure that our components are distributed responsibly, manufacturers, distributors, and consumers are reminded that finished power chairs must comply with a variety of standards and requirements for governmental safety and functionality.

If it is necessary to physically modify a power chair, including the addition of third-party componentry (including seat backs, seats, other accessories, and or positioning components), to accommodate the medical needs of the power chair occupant, a risk assessment in conformance with ISO 14971, as outlined in ISO 7176, should be performed.

## Introduction

### MANDATORY!

The following information pertains to power chairs equipped with a factory-installed Pride Transit Securement Package, whether designed to accommodate “Occupied” or “Unoccupied” transportation of your power chair in a motor vehicle, as described in detail below. Read this information in its entirety before use of the Pride Transit Securement System as an Occupied seat in a motor vehicle. If you have any questions about this information or about using the Pride Transit Securement System with your power chair as a seat in a motor vehicle, contact your authorised Pride/Quantum Rehab Provider.

The Occupied Pride Transit Securement System conforms with the standard of ANSI/RESNA WC/Vol. 4, Section 19/ISO 7176-19 for the purpose of enabling power chairs to be secured in certain types of motor vehicles. The Pride Transit Securement System, including manufacturer installed front and rear securement brackets and pelvic belt anchoring brackets, has been crash tested in accordance with ANSI/RESNA WC/Vol. 4, Section 19/ISO 7176-19, Frontal Impact Test, with a 170-lb. (76.3-kg) surrogate occupant, which represents a user weight of 165-300-lb. (75 to 136-kg), or a 225-lb. (102.0-kg) surrogate occupant, which represents a user weight of >300-lb. (>136-kg).

Notwithstanding this standard and testing conformance, many government transportation agencies, at the time of publication, have not approved any securement system of an occupied power chair in a motor vehicle. Therefore, it is the position of Pride Mobility Products that the Transit Securement Package should only be utilised to secure an occupied power chair being transported in a motor vehicle at the user’s discretion and in accordance with ISO 7176-19 standards, which are intended to increase safety, but do not suggest that compliance with the standards will necessarily prevent serious injury or death of a secured power chair occupant during motor vehicle transport.

In accordance with ISO 7176-19 standards, the power chair user should transfer into the vehicle seat and use the vehicle-installed belt restraint system if and whenever feasible.

The Transit Securement Package is only available when factory-installed on new power chairs, and cannot be retrofitted on existing power chairs or serviced in the field.

### PROHIBITED!

Do not modify your power chair in any way not authorised by Pride/Quantum. Do not make alterations or substitutions to power chair structural parts or frame components without consulting Pride/Quantum. Do not add any accessories to a power chair equipped with a factory-installed Pride Transit Securement System without first consulting Pride/Quantum Rehab.

### WARNING!

The primary goal of AS/NZ 3696.19 is to reduce the potential for injury to wheelchair-seated occupants in the event of a vehicle impact. An additional goal is to address wheelchair performance related to normal vehicle operating conditions. Any modifications or additions to the wheelchair (such as changes to the frame, after-market cushions, harnesses) may reduce its safety in a vehicle accident. If unsure of their effect, the operator should consult a suitably qualified professional for advice.

## Label Information



Read and follow the information in the owner's manual and all supplemental information provided with the power chair before initial operation.



Indicates that the power chair or power chair component (base or seating system) contains a Transit Securement System that conforms to ISO 7176-19 for transport of an Occupied power chair in a motor vehicle.



Indicates power chair with similar label is not rated for occupied transit.



Indicates **OCCUPIED** power chair securement points.



Indicates **UNOCCUPIED** power chair securement points.



**WARNING!** Indicates a potentially hazardous condition/situation. Failure to follow designated procedures can cause either personal injury, component damage or malfunction. On the product, this icon is represented as a black symbol on a yellow triangle with a black border.



**MANDATORY!** These actions should be performed as specified. Failure to perform mandatory actions can cause personal injury and/or equipment damage. On the product, this icon is represented as a white symbol on a blue dot with a white border.



**PROHIBITED!** These actions are prohibited. These actions should not be performed at any time or in any circumstances. Performing a prohibited action can cause personal injury and/or equipment damage. On the product, this icon is represented as a black symbol with a red circle and red slash.



**IMPORTANT!** Indicates important information to remember when using this product.

## Definitions

- **ISO:** International Standards Organization (<http://www.iso.org>)
- **Securement Points:** Specific structural points on the power chair base or seat frame that are designed for attachment of a WTORS. These securement points are indicated by anchor symbols.
- **Transit Securement Package:** Equipment installed on the power chair which allows the power chair to be anchored in a motor vehicle. The equipment consists of tie-down anchor points and may include a pelvic belt. The equipment differs depending on whether the Transit Securement System is intended to accommodate Occupied vs. Unoccupied transport of the power chair in a motor vehicle.
- **Wheelchair Tie-down and Occupant Restraint System (WTORS):** Equipment installed in a motor vehicle which allows a power chair and/or a power chair-seated occupant to be anchored in the motor vehicle for limiting occupant movement in a motor vehicle crash. The equipment consists of a system or device for securing the power chair and a belt-type restraint system.

## User Safety Information

### MANDATORY!

Always secure the power chair and occupant in a forward-facing position in the vehicle.

The power chair should be used as indicated in the manufacturer's instructions. If you have any questions about the proper use of your power chair, contact your authorised Pride/Quantum Rehab Provider.

Only belt restraints that comply with the provisions of ISO 7176-19 and that have been dynamically tested in accordance with this standard should be installed on the power chair for use as a restraint in a motor vehicle.

### WARNING!

If the total power chair mass is greater than 275 bs. (125 kg), then transport in a motor vehicle with a gross vehicle weight greater than 8,800 lbs. (4,000 kg) is recommended if the option exists.

### Protocols and Procedures

The power chair user should transfer into the vehicle seat and use the vehicle-installed restraint system if and whenever feasible. The power chair should then be stored and secured in the vehicle.

For users choosing to remain in their power chair during motor vehicle transport, in addition to the Pride Transit Securement System for Occupied transport, the vehicle must be equipped with a Wheelchair Tie-down and Occupant Restraint System (WTORS) that has been installed in accordance with the tie-down manufacturer's instructions, and is compliant with ISO 10542 standards. It is essential to use a complete WTORS to secure the power chair to the vehicle. In addition to compliance with the above standards, the WTORS must be equipped with both pelvic and upper-torso belts to protect the power chair occupant and minimise the likelihood of injury caused by contact with the vehicle during a crash or sudden braking.

### WARNING!

Only power chairs marked with this symbol are rated for occupied use.

### WARNING!

If the total power chair mass is greater than 125 kg (275 lbs.), then it is recommended that two additional ISO 10542 compliant rear securement straps be used to anchor the power chair during motor vehicle transport.

## Securing the Power Chair (Unoccupied)

**NOTE:** In addition to following the general guidelines below, be sure to follow all warnings, instructions, and recommendations provided by the WTORS manufacturer.

- Always secure the power chair in a forward-facing position in the vehicle.
- Attach the four, six, or eight tie-down straps only to designated, labeled transit securement points indicated by anchor symbols on the power chair. **See figures 1 through 9.** Tighten the straps to sufficiently remove all slack.
- Never attach tie-downs to adjustable, moving, or removable parts of the power chair such as armrests, front riggings and wheels.
- Position the anchor points for the rear tie-down straps directly behind the rear securement points on the power chair. The front tie-down straps should anchor to floor points that are spaced wider than the power chair to provide increased lateral stability. **See figure 1.**

### **⚠ WARNING!**

Ensure power chairs equipped with a Pride Transit Securement System are properly secured to the motor vehicle during transport. Power chairs that are not properly secured can become a hazard to the user and to other vehicle passengers in the event of a crash, sudden stopping or swerving, as the power chair could tip or slide out of place.

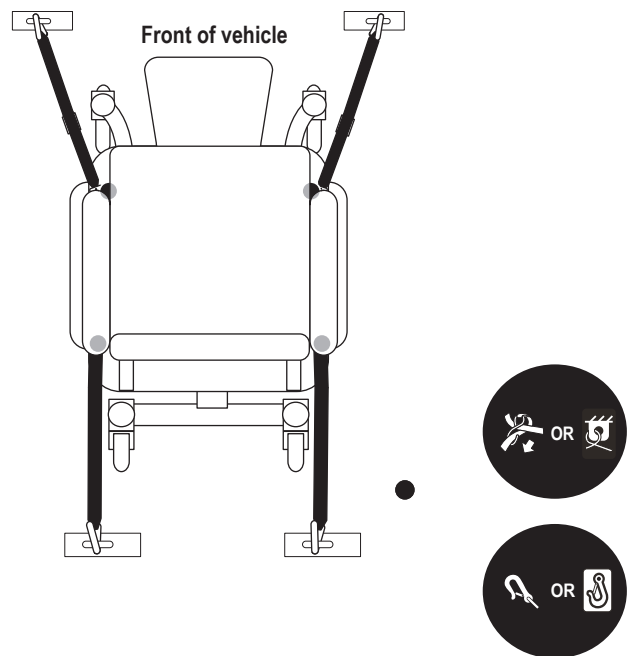

Figure 1. Securing the Power Chair

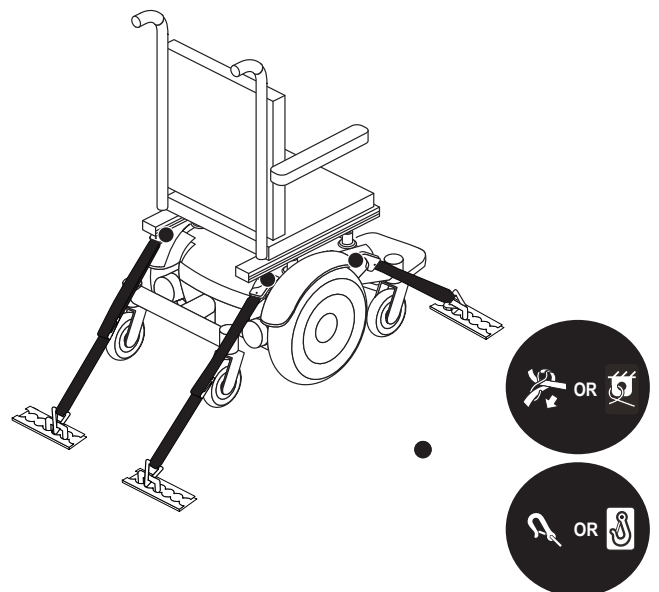
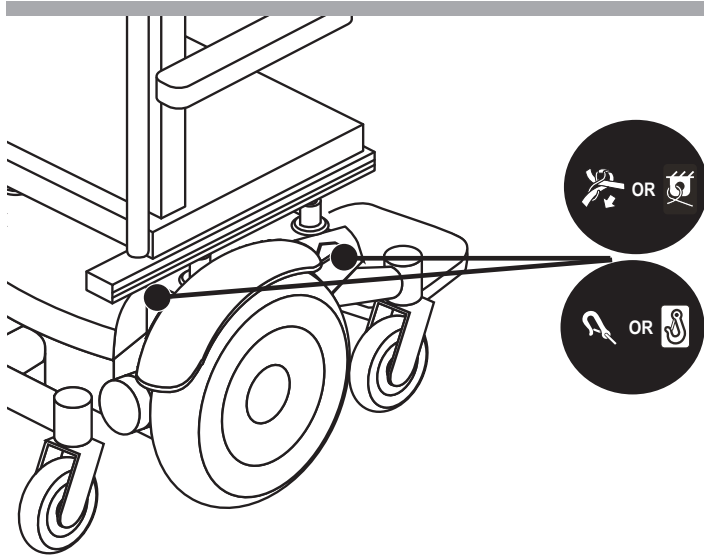

Figure 2. Tie-down System

**Unoccupied and Occupied Securement Points**

■ The Pride Transit Securement Package includes WTORS belt restraint anchor points in conformance with ISO 7176-19. **See figures 3 through 9** for the location of the anchor points on each model.



**Models:**

- Q6 Edge HD with Synergy Seat & Bariatric Tilt
- Q6 Edge HD with TRU-Comfort Seat & Bariatric Tilt
- Q6 Edge HD with TRU-Balance 3 Seat (all configurations)
- Q6 Edge Z with TRU-Balance 3 Seat (all configurations)

**Figure 3. 4-Point Securement Points on a Mid-wheel Drive Power Chair (Right Side Shown)**

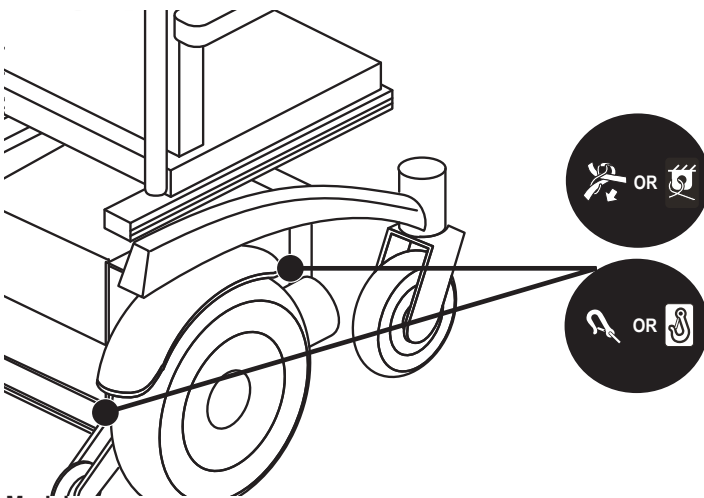

**Models:**

- Quantum R44 Flex with Static and Tilt
- Aspen Flex with Static, Tilt or Recline

**Figure 4. 4-Point Securement Points on a Rear-wheel Drive Power Chair (Right Side Shown)**

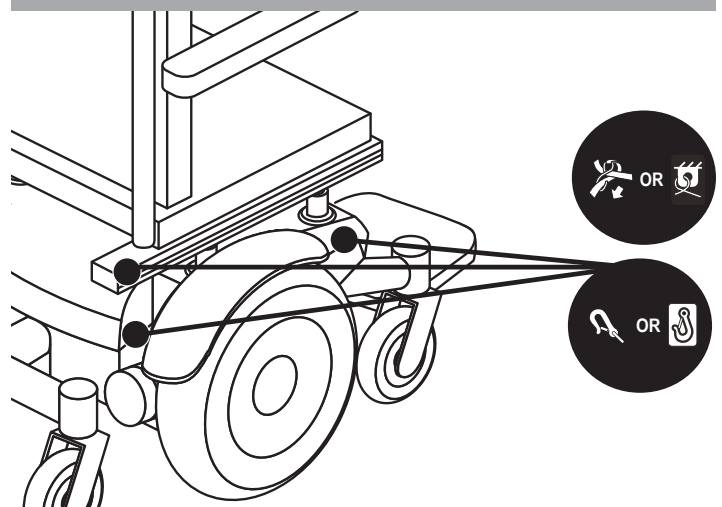

**Models:**

- Q6 Edge 3 Stretto with TRU-Balance 3 Seat (all configurations)
- Q6 Edge 3 Stretto with TRU-Balance 3 Flex Static and Tilt
- Q6 Edge 3 Stretto with Contoured Seat
- Q6 Edge 2.0 with TRU-Balance 3 Seat (all configurations)
- Q6 Edge 2.0 with Synergy Seat - Static
- Q6 Edge 3 with TRU-Balance 3 Seat (all configurations)
- Q6 Edge Z with TRU-Balance 3 Seat (all configurations)
- Quantum 4 Front/4 Front 2 with TRU-Balance 3 Seat (all configurations)
- J623 2.0 with TRU-Balance 3 Seat (all configurations)
- J623 2.0 with Synergy Seat - Static
- Q6 Edge 4 with TRU-Balance 3 Seat (all configurations)
- Q6 Edge 4 with TRU-Balance 4 Seat (all configurations)

**Figure 5. 6-Point Securement Points on a Mid-wheel Drive Power Chair (Right Side Shown)**

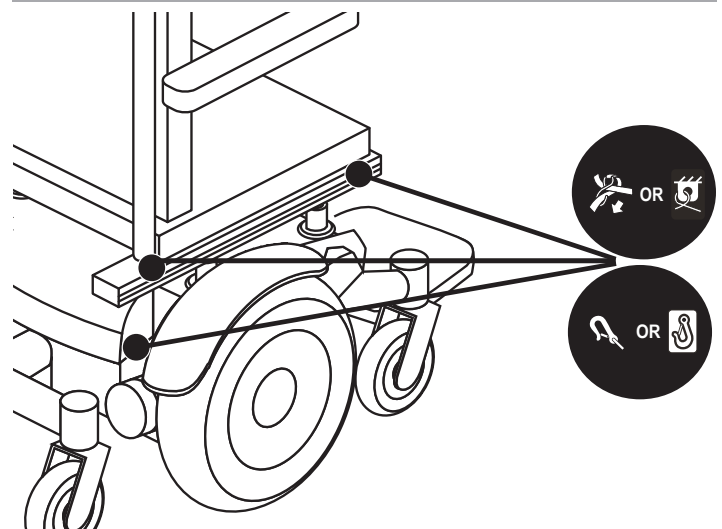

**Models:**

- Q6 Edge HD with Synergy Seat and Bariatric Tilt
- Q6 Edge HD with TRU-Comfort Seat and Bariatric Tilt

**Figure 6. 6-Point Securement Points on a Mid-wheel Drive Power Chair (Right Side Shown)**

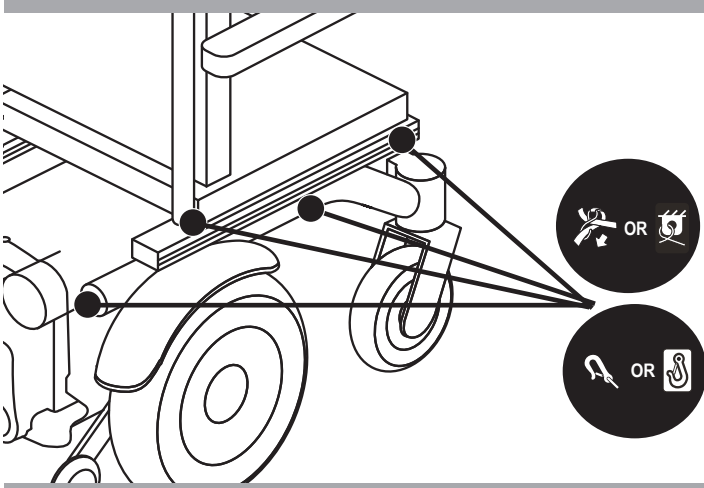

Figure 7. 8-Point Securement Points on a Rear-wheel Drive Power Chair (Right Side Shown)

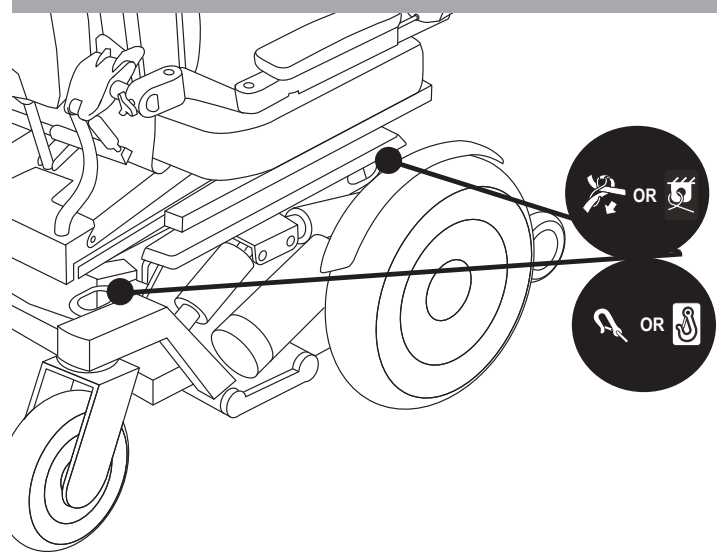
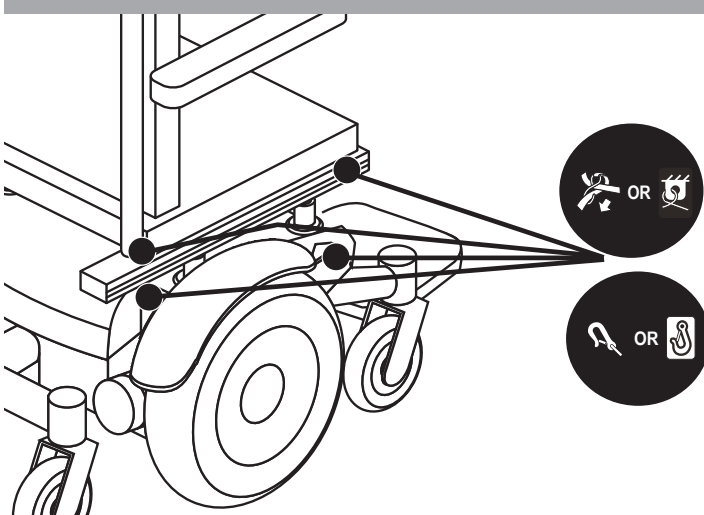

Figure 9. 4-Point Securement Points on a Front-wheel Drive Power Chair (Right Side Shown)



**Models:**

- Q6 Edge 2.0 with Synergy Seat and TRU-Balance 2 Tilt
- Q6 Edge 2.0 with Synergy Seat and TRU-Balance 2 10-in Lift and Tilt
- Q6 Edge 2.0 with TRU-Comfort Seat and TRU-Balance 2 Tilt
- Q6 Edge 2.0 with TRU-Comfort Seat and TRU-Balance 2 10-in Lift and Tilt
- Q6 Edge HD with TRU-Balance 3 Seat and iLevel 10-in Lift and Tilt
- J623 2.0 with Synergy Seat and TRU-Balance 2 Tilt
- J623 2.0 with Synergy Seat and TRU-Balance 2 10-in Lift and Tilt
- J623 2.0 with TRU-Comfort Seat and TRU-Balance 2 10-in Lift and Tilt
- J623 2.0 with TRU-Comfort Seat and TRU-Balance 2 Tilt

Figure 8. 8-Point Securement Points on a Mid-wheel Drive Power Chair (Right Side Shown)

**Securing the Power Chair Occupant (Applies to Transit Securement Systems Designed to Accommodate for Occupied Transport Use Only)**

Once the power chair has been properly secured, it is essential that the power chair occupant be protected for transport.

**⚠ WARNING!**

The power chair occupant must be secured with dynamically crash-tested and approved pelvic and upper-torso belts or with a five-point child restraint harness as part of WTORS.

- Always secure the power chair occupant in a forward-facing position in the vehicle with a crash-tested pelvic belt that is anchored to the seat frame; complete the restraint system by attaching the lower end of the WTORS upper-torso belt to the pelvic belt by referring to the WTORS manufacturer’s instruction.
- Place the pelvic belt across the front of the pelvis near the upper thighs, not high over the abdomen.

**⚠ WARNING!**

The pelvic belt should be angled between 45 degrees and 75 degrees to the horizontal when viewed from the side. However, if the user cannot achieve this standard, an optional zone of 30 degrees to 45 degrees can be utilised safely.

- The frontal clear zone (FCZ) is measured from the forwardmost point on the occupant’s head and should measure at least 66 cm (26 in.) if both a pelvic and upper-torso belt are used. See figure 11.

**NOTE: The recommended frontal clear zone may not be achievable for power chair-seated vehicle operators.**

- The rear clear zone (RCZ) is measured from the rearmost point on the occupant’s head and should measure at least 40.64 cm (16 in.). See figure 11.
- The seated head height (HHT) ranges from about 120 cm (47 in.) for a small adult female to about 155 cm (61 in.) for a tall adult male. See figure 11.

**⚠ WARNING!**

Always allow for proper clear zones when securing an occupied power chair in a motor vehicle.

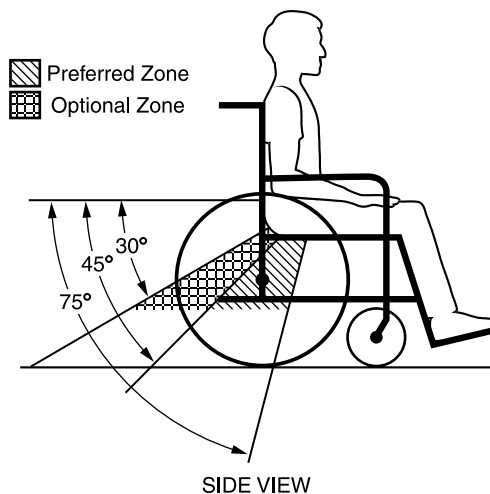

Figure 10. Recommended Pelvic Belt Placement Angles

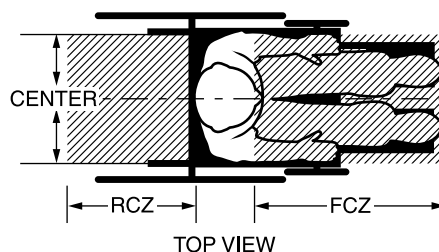
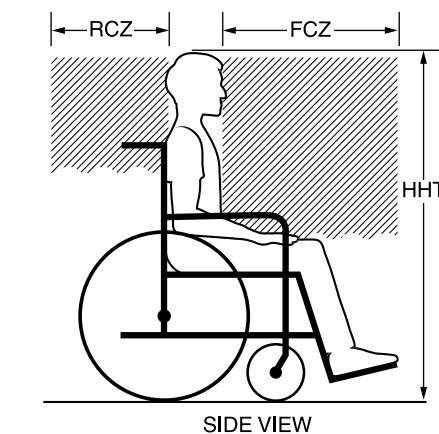

Figure 11. Recommended Clear Zones for Power Chair-seated Occupants

**⚠ WARNING!**

Allow as much clearance as possible around the power chair occupant to reduce the possibility of contact with vehicle components and other passengers in the event of a crash.

Ensure all vehicle components that are in close proximity to the power chair occupant are removed or covered with dense padding.

**NOTE:** For a WC-19 crash-test-approved belt, please contact Qstraint at [www.qstraint.com](http://www.qstraint.com) or 1-800-987-9987.

- Some power chair components, like armrests and wheels, can interfere with proper belt fit. It may be necessary to insert the belt between the armrest and the seatback or through openings between the backrest and seat in order to avoid placing the pelvic belt over the armrest. **See figure 12.**
- Place the upper-torso belt across the middle of the shoulder and the center of the chest, and connect to the pelvic belt that is secured to the floor of the vehicle. **See figure 13.**

**⚠ WARNING!**

The upper-torso belt webbing should not be worn twisted in a manner that reduces the area of contact of the belt with the occupant.

- The use of the postural pelvic belts attached to the power base or seat frame is encouraged during travel, but these belts should be positioned so that they do not interfere with the proper positioning of crashworthy belt restraints and should not be relied on for occupant protection in crash situation unless the postural belt complies with the requirements of ISO 7176-19.
- The upper-torso belt anchor point should be anchored above and behind the top of the power chair occupant's shoulder to ensure that the occupant is properly restrained during transport. Both the pelvic and upper-torso belt restraints should be adjusted as snugly as possible consistent with user comfort.

**⚠ WARNING!**

The buckle of belt restraint systems should not be located near power chair components that may come in contact with the buckle release button in the event of a vehicle accident or collision.

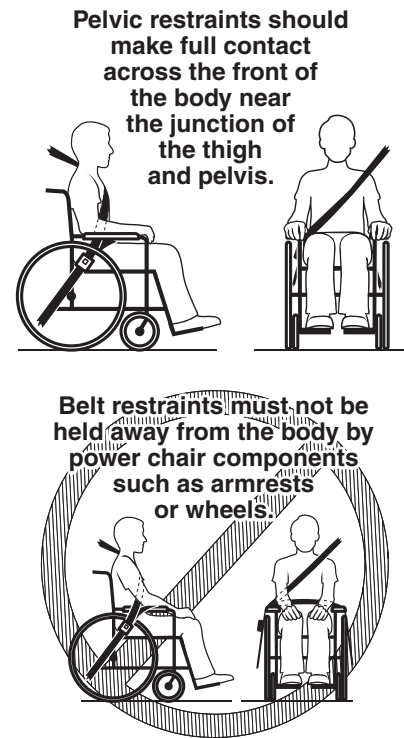

Figure 12. Proper Pelvic Belt Placement

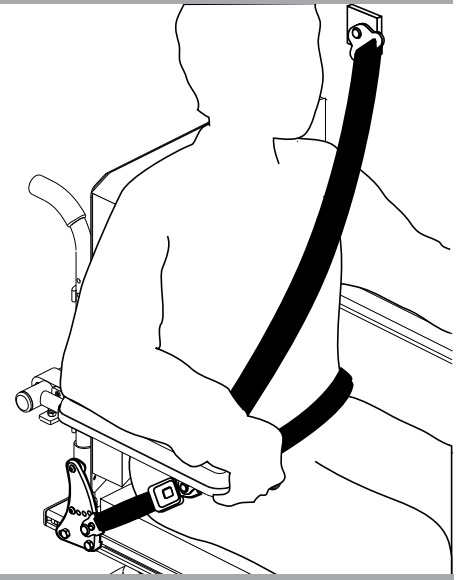

Figure 13. Proper Upper-torso Belt Placement

- If your power chair is equipped with a crash-tested pelvic belt that is anchored to the seat frame, complete the restraint system by attaching the lower end of the WTORS upper-torso belt to the pelvic belt by referring to the WTORS manufacturer's instruction. Crash-tested power chair-anchored pelvic belts will be labeled to indicate compliance to the ISO 7176-19 standards. **See figure 14.**

### MANDATORY!

A vehicle-anchored belt restraint system conforming to ISO 10542 must be used if the power chair occupant chooses not to utilise a manufacturer-installed power chair-anchored belt restraint system or if it is not available on the system. Contact the belt restraint system manufacturer to confirm certification prior to use.

### WARNING!

Although postural supports and belts may be used in a moving vehicle in addition to the occupant belt restraint system, they should not be relied upon to replace occupant restraints that have been designed and tested for this purpose and should not interfere with proper belt restraint placement.

### Transit Securement System

The following components of the transit securement package must be compliant to ISO 10542 standards and must be installed according to the manufacturer's instructions.

- Wheelchair Tie-down and Occupant Restraint System (WTORS)
- 4-point, 6-point, or 8-point power chair tie-down system with an integrated 3-point occupant restraint
- Tie-down end fittings
- WTORS securement points
- Occupant restraint securement points

**NOTE:** To obtain a copy of ISO 7176-19 or ISO 10542 visit [www.iso.org](http://www.iso.org).

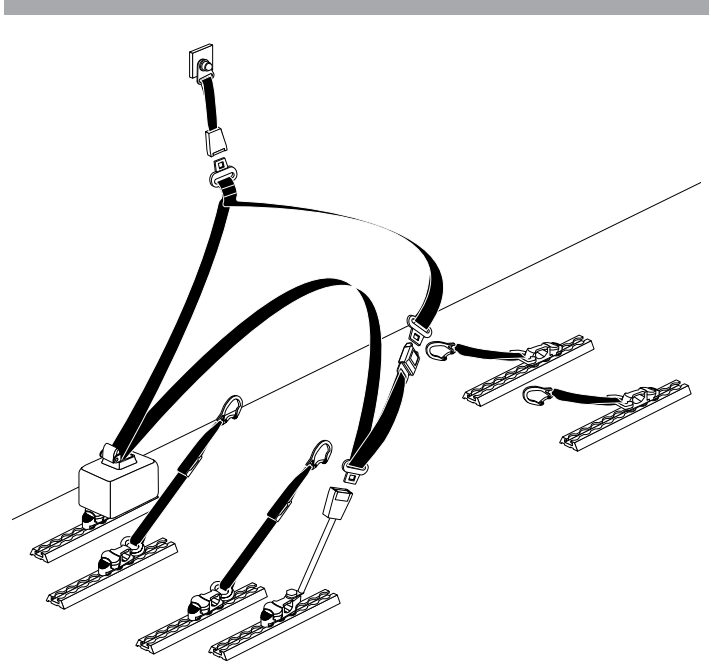

Figure 14. Vehicle-anchored Belt Restraint

## Important Points to Remember (Unoccupied and Occupied)

### MANDATORY!

Read and follow all manufacturer's instructions, including the product owner's manual.

### MANDATORY!

Any WTORS or power chair involved in a vehicle crash should be replaced.

### WARNING!

The power chair seat should never be raised or elevated while the power chair is secured in a vehicle for occupied or unoccupied transit. Failure to heed may result in personal injury and/or property damage.

The power chair seatback should be positioned at an angle of no more than 30 degrees to the vertical. If a greater recline angle is required, the upper-torso belt anchor point should be moved rearward along the vehicle's sidewall to ensure that the belt maintains contact with the power chair occupant's shoulder and chest.

Visually inspect all WTORS equipment according to WTORS manufacturer's instructions on a regular basis, and have worn or broken components replaced immediately. Ensure anchorage track is free of dirt and debris.

Ensure that any removable components are securely attached to the powerchair and remove and stow all removable accessories elsewhere in the vehicle to reduce the chance of power chair occupant injury.

Contents of non-removable accessories should also be stowed.

Consider using foam trays in place of rigid trays during vehicle transport. If that is not possible, place dense foam padding between the power chair occupant and the tray, and make sure that the tray is securely attached to the power chair so that it will not break loose and cause injury to other occupants in a crash.

### WARNING!

Ensure the power chair occupant is properly positioned to protect the neck during rear impact.

Secure all removable accessories, including clothing guards, medical and other equipment to the power chair or vehicle, to prevent injury during a crash.

If head and neck support is required during travel, use a soft, light neck collar as they are less likely to cause neck injury in a crash. Do not attach the soft collar to the power chair or seating system.

## Appendix: Declarations

### Pride Occupied Transit Securement Package Declarations

---



**MANDATORY!** A belt restraint system with both pelvic and upper-torso belts must be used to protect the power chair occupant and minimise the likelihood of injury caused by contact with the vehicle during a crash or sudden braking.



The occupied power chair was dynamically tested in a forward-facing position with the surrogate occupant restrained by both pelvic and upper-torso belts and conforms with ISO 10542 requirements.

---

**NOTE:** For additional model specific information, such as overall unit size, weight, turning radius, etc., refer to the product specification sheet included with your power chair owner's manual.

**NOTE:** Other configurations are considered WC-19 and/or ISO 7176-19 compliant. Contact your Quantum Rehab Provider for more information.







# Transit Securement Systems Guide

## **USA**

401 York Avenue  
Duryea, PA 18642  
[www.quantumrehab.com](http://www.quantumrehab.com)

## **Canada**

5096 South Service Road  
Beamsville, Ontario L3J 1V4  
[www.quantumrehab.ca](http://www.quantumrehab.ca)

## **Australia**

20-24 Apollo Drive  
Hallam, Victoria 3803  
[www.quantumrehab.com.au](http://www.quantumrehab.com.au)

## **New Zealand**

391 Neilson Street  
Penrose, Auckland 1061  
[www.pridemobility.co.nz](http://www.pridemobility.co.nz)

## **UK**

(Authorised UK Representative)  
32 Wedgwood Road  
Bicester, Oxfordshire OX26 4UL  
[www.quantumrehab.co.uk](http://www.quantumrehab.co.uk)

## **The Netherlands**

(Authorised EU Representative)  
De Zwaan 3  
1601 MS Enkhuizen  
[www.quantumrehab.eu](http://www.quantumrehab.eu)  
[www.quantumrehab.nl](http://www.quantumrehab.nl)

## **Switzerland**

(Authorised CH Representative)  
SODIMED SA  
Chemin Praz Devant 12  
1032 Romanel-sur-Lausanne

## **Italy**

Via della Tecnica, 3  
00065 Fiano Romano-ROMA  
[www.quantumrehab-italia.it](http://www.quantumrehab-italia.it)

## **France**

26 Rue Monseigneur Ancel  
69800 Saint-Priest  
[www.quantumrehab.fr](http://www.quantumrehab.fr)

## **Spain**

Calle Las Minas Número 67  
Polígono Industrial Urtinsa II, de Alcorcón  
28923 Madrid  
[www.quantumrehab.es](http://www.quantumrehab.es)

## **Germany**

Josef-Förster-Straße 6-8  
33161 Hövelhof  
[www.quantumrehab.de](http://www.quantumrehab.de)

## **China**

Room 508, Building #4  
TianNa Business Zone  
No. 500 Jianyun Road  
Pudong New Area  
Shanghai 201318  
[www.pridechina.cn](http://www.pridechina.cn)

